

Swiss Fliegertruppe 1914-1936

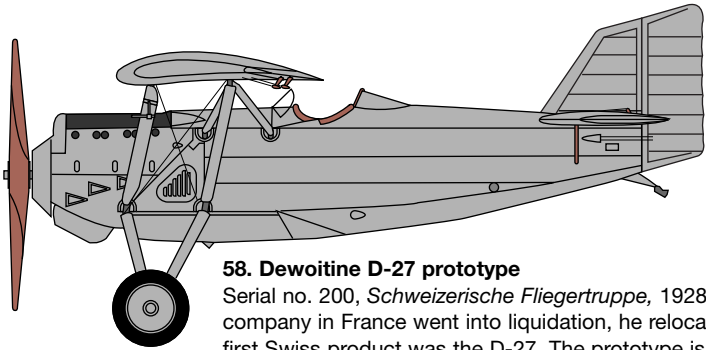

58. Dewoitine D-27 prototype

Serial no. 200, *Schweizerische Fliegertruppe*, 1928. When Emile Dewoitine's company in France went into liquidation, he relocated to Switzerland in 1927. His first Swiss product was the D-27. The prototype is finished in an overall Natural Metal/Aluminium Dope colour scheme. No national markings were carried at this early stage in no. 200's career. Propeller is Varnished Laminated Wood. Note the angular fin and rudder, which was altered in subsequent production machines. No. 200 continued to serve with the *Fliegertruppe* until 1936, when it crashed while being used for aerobatic training.

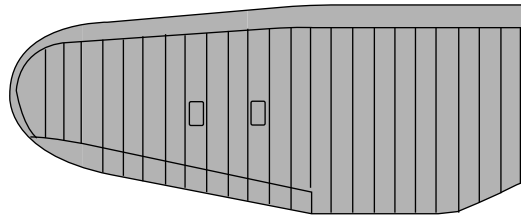

59. Dewoitine D-27 III

Serial no. 203, *Schweizerische Fliegertruppe*, 1932. This 0-Serie Dewoitine D-27 is finished in an overall Natural Metal/Aluminium Dope colour scheme. Swiss national colours consisting of a White cross on a Red field are carried on upper and lower wing surfaces. The top half of the rudder is Red with a White cross. Serial number is Black. Propeller is Varnished Laminated Wood. Note the curved tail profile on this production machine in comparison to the prototype.

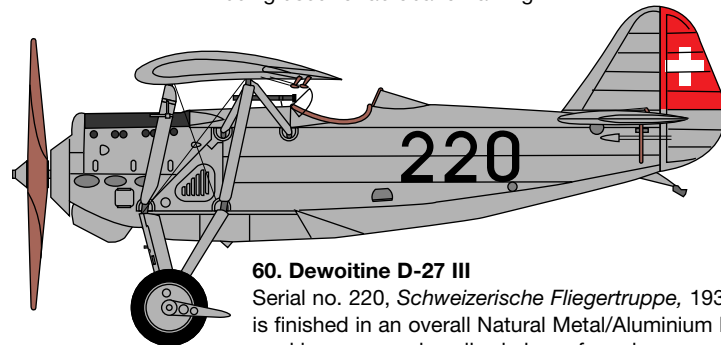
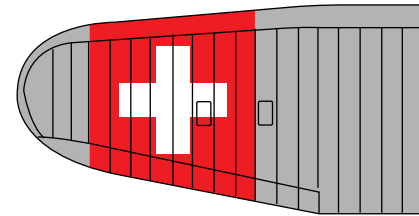

60. Dewoitine D-27 III

Serial no. 220, *Schweizerische Fliegertruppe*, 1932. This 1-Serie Dewoitine D-27 is finished in an overall Natural Metal/Aluminium Dope colour scheme. National markings are as described above for scheme no. 59. Serial number is Black. Propeller is Varnished Laminated Wood. Note the widened main undercarriage legs, the spinner and the additional fuselage panels.

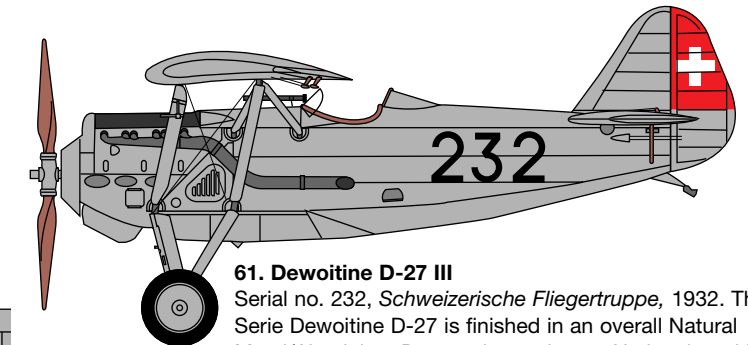

61. Dewoitine D-27 III

Serial no. 232, *Schweizerische Fliegertruppe*, 1932. This 2-Serie Dewoitine D-27 is finished in an overall Natural Metal/Aluminium Dope colour scheme. National markings are as described for scheme no. 59. Serial number is Black. Propeller is Black. Note the addition of exhaust pipes and a metal propeller on this fighter/bomber version.

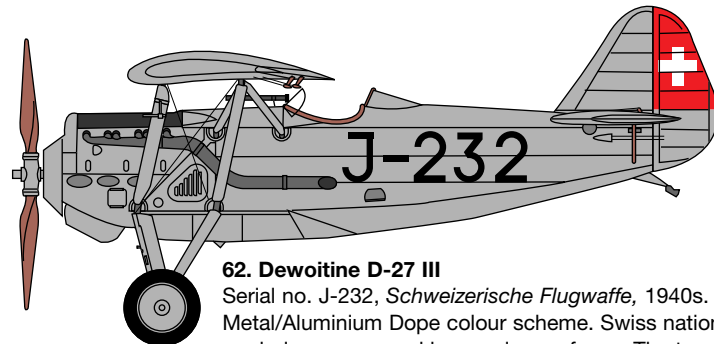

62. Dewoitine D-27 III

Serial no. J-232, *Schweizerische Flugwaffe*, 1940s. This 2-Serie Dewoitine D-27 is finished in an overall Natural Metal/Aluminium Dope colour scheme. Swiss national colours consisting of a White cross on a Red roundel are carried on upper and lower wing surfaces. The top half of the rudder is Red with a White cross. Serial number is Black. Propeller is Black. Note the application of the Swiss serial number after 1934, and the wing roundels.

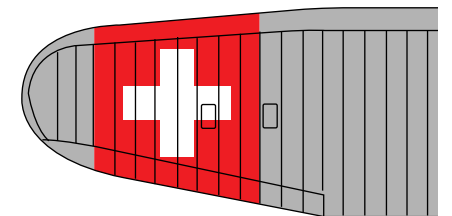
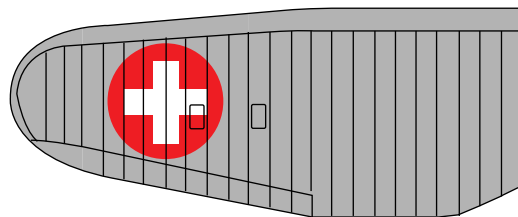

Swiss Fliegertruppe 1914-1936

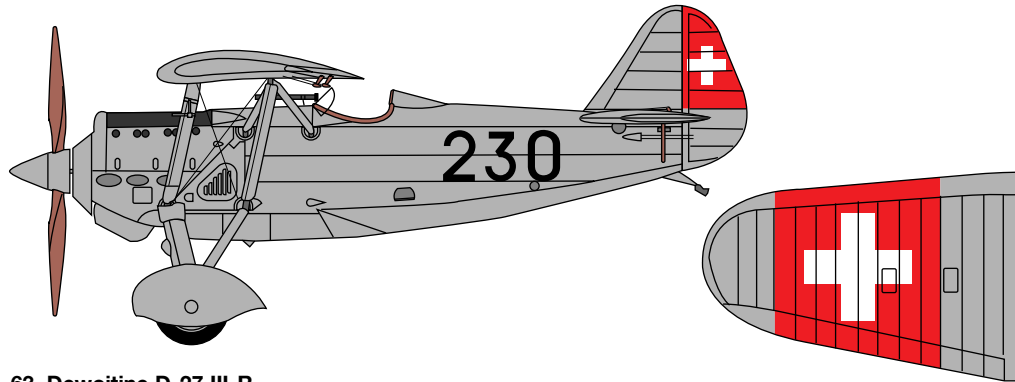

63. Dewoitine D-27 III-R

Serial no. 230, *Schweizerische Fliegertruppe*, 1933. This Dewoitine D-27 III-R is finished in an overall Natural Metal/Aluminium Dope colour scheme. Swiss national colours consisting of a White cross on a Red field are carried on upper and lower wing surfaces. The top half of the rudder is Red with a White cross. Serial number is Black. Propeller is Natural Metal. Note the spinner and spatted undercarriage.

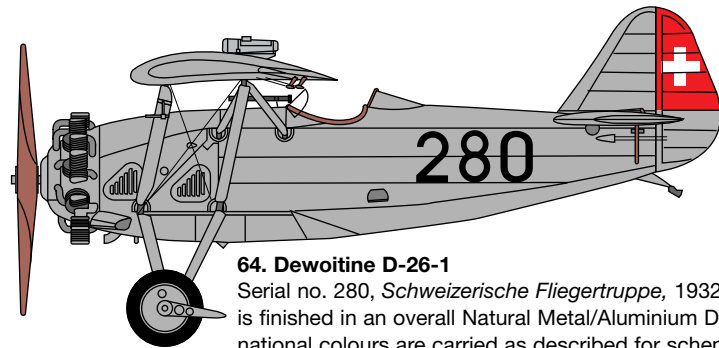

64. Dewoitine D-26-1

Serial no. 280, *Schweizerische Fliegertruppe*, 1932. This Dewoitine D-26-1 trainer is finished in an overall Natural Metal/Aluminium Dope colour scheme. Swiss national colours are carried as described for scheme no. 63. Propeller is Varnished Laminated Wood. Note the gunnery camera mounted on the upper wing centre section. Only no. 280 and 290 were fitted with the camera, as well as an uprated 300hp powerplant.

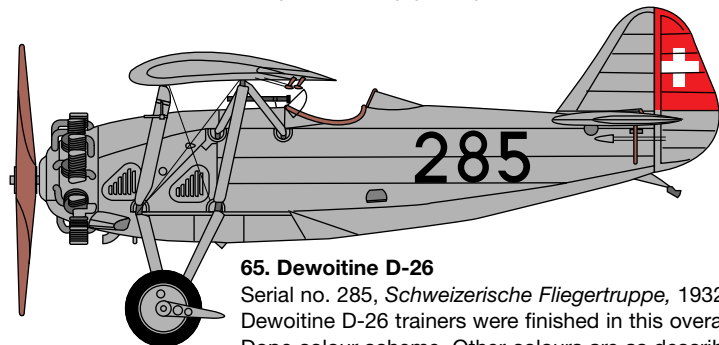

65. Dewoitine D-26

Serial no. 285, *Schweizerische Fliegertruppe*, 1932. The remaining nine Dewoitine D-26 trainers were finished in this overall Natural Metal/Aluminium Dope colour scheme. Other colours are as described above.

Table 4: Dewoitine aircraft in Swiss *Fliegertruppe* Service 1925-1948

Serial range	Aircraft type	Delivered	Engine/notes
200	Dewoitine D-27	1928	500hp Hispano-Suiza HS-57 12-Mb. Prototype. After 1934 reserialled as J-200
201-205	Dewoitine D-27 III	1931	500hp Hispano-Suiza HS-57 12-Mb. 0-Serie. After 1934 reserialled as J-201 to J-205
206-220	Dewoitine D-27 III	1931	500hp Hispano-Suiza HS-57 12-Mb. 1-Serie. Improved version with strengthened undercarriage. After 1934 reserialled as J-206 to J-220
221-265	Dewoitine D-27 III	1932	500hp Hispano-Suiza HS-57 12-Mb. 2-Serie. Improved version with strengthened undercarriage, metal propeller, exhaust pipes and bomb racks for use as fighter bomber. After 1934 reserialled as J-221 to J-265
216-230	Dewoitine D-27 III-R	1932	570hp Hispano-Suiza HS-57 12-Mc. Rebuilt aircraft with new engine, undercarriage spats and streamlined propeller. After 1934 reserialled as J-216 to J-230
280, 290	Dewoitine D-26-1	1931	300hp Wright Qc radial. Fitted with gunnery training camera. After 1934 reserialled as U-280 and U-290
281-289	Dewoitine D-26	1931	250hp Wright Qa radial. After 1934 reserialled as U-281 to U-289
671, 672	Dewoitine D-1 C-1	1925	300hp Hispano-Suiza HS-42 8-Fb. Originally registered as F-AHAC and F-AHAD for delivery
673-675	Dewoitine D-19 C-1	1926	400hp Hispano-Suiza HS-52 12-Jb. 674 and 675 assembled in Switzerland by EKW
676-678	Dewoitine D-9 C-1	1928	420hp Cosmos-Bristol Jupiter 9 Ab Mk IV. Assembled in Switzerland by EKW
680	Alfred Comte AC-1	1928	420hp Bristol Jupiter 9 Abx Mk IV. Originally registered as CH-174. Prototype fighter that incorporated some Dewoitine D-9 C-1 flying surfaces

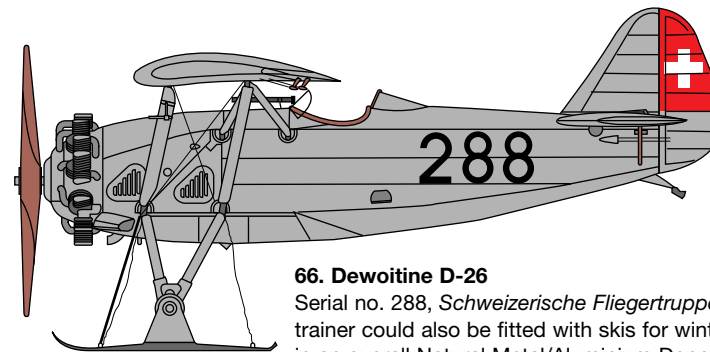

66. Dewoitine D-26

Serial no. 288, *Schweizerische Fliegertruppe*, 1932. The Dewoitine D-26 trainer could also be fitted with skis for winter use. The machine is finished in an overall Natural Metal/Aluminium Dope colour scheme. National markings are as described above for scheme no. 63. Serial number is Black. Propeller is Varnished Laminated Wood. Skis are Dark Grey/Black .

Swiss Fliegertruppe 1914-1936

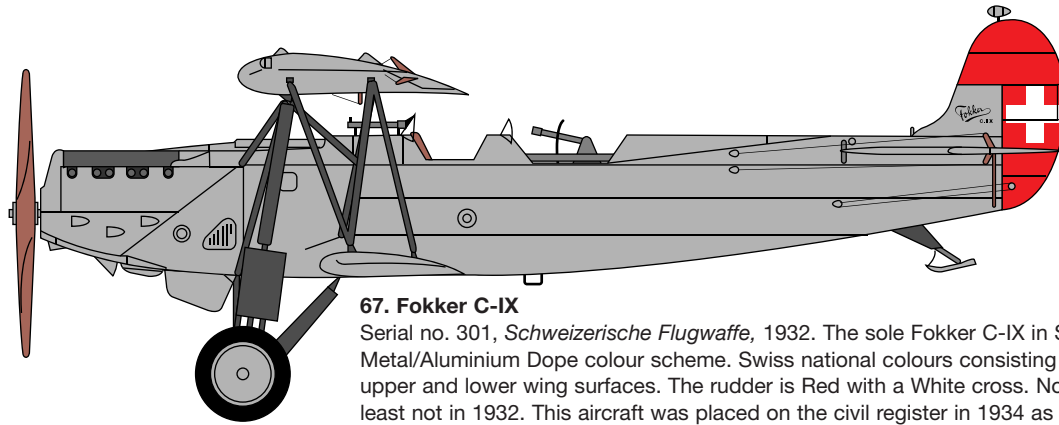

67. Fokker C-IX

Serial no. 301, *Schweizerische Flugwaffe*, 1932. The sole Fokker C-IX in Swiss use was finished in an overall Natural Metal/Aluminium Dope colour scheme. Swiss national colours consisting of a White cross on a Red field are carried on upper and lower wing surfaces. The rudder is Red with a White cross. No serial number appears to have been carried, at least not in 1932. This aircraft was placed on the civil register in 1934 as CH-301. It continued to serve until 1947. Propeller is Varnished Laminated Wood. Struts are Dark Grey/Black.

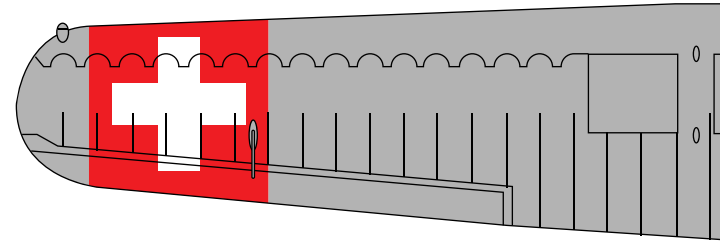

Series references

The following reference sources have been used in the compilation of this series: *Die Flugzeuge der schweizerischen Fliegertruppe seit 1914*, Jakob Urech & Emil Hunziker, Verlag Th. Gut & Co., 1974; *The Complete Book of Fighters*, William Green & Gordon Swanborough, Salamander 1994; *Fighters between the Wars 1919-1939*, Kenneth Munson, Blandford, 1970; *Fokker: Aircraft Builders to the World*, Thijs Postma, Jane's Incorporated, 1980; *Profili di Aerei Militari della 1a Guerra Mondiale*, Giorgio Apostolo & Giorgio Bignozzi, Fratelli Fabbri Editori, 1973; *Air Forces of the World*, William Green and John Fricker, Macdonald 1958; *Warplanes of the World*, Michael J H Taylor, Ian Allan 1981; *Icare No. 52: l'aviation suisse*, Icare/SNPL, 1969; *Potez 25*, Pierre Cortet & others, Avions, 1996; various issues of *Small Air Forces Observer*, Profile Publications, *Windsock Magazine*, *WW1 Aero* and others.

Any amendments, corrections and additions will be gratefully received by the publishers, and will be incorporated into future updates of this eBook.

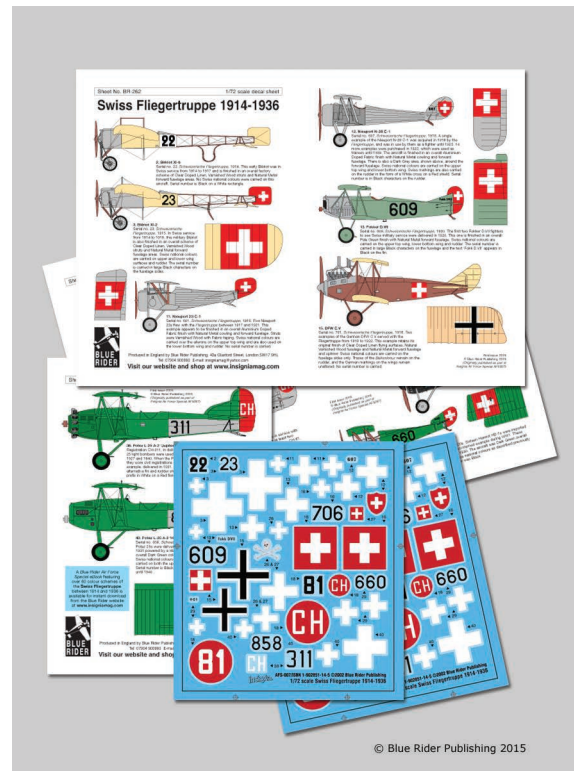

Decal sheet BR262, featuring markings for 13 aircraft from this eBook, is now available from our website at www.insigniamag.com